

SP 2300

 **CORGHI**
Made in Italy



Disponibile anche versione WDK
WDK version also available
Auch in WDK-Ausführung erhältlich

 **Dispositivo multifunzionale universale**
per agevolare montaggio e smontaggio dello pneumatico

 **Universal multifunctional device**
for facilitating tyre mounting and demounting

 **Universelle Mehrzweckvorrichtung**
zur Erleichterung der Reifenmontage und demontage

 **CORGHI**
seguì Corgi - follow Corgi

SP2300 Standard

SP2300 WDK



Il dispositivo **SP2300** è un comodo e funzionale Helper appositamente studiato per rendere le operazioni di montaggio e smontaggio più veloci precise e sicure.

Disponibile in due versioni:

- SP2300 **Standard**, composta da tre unità operative integrate in grado di lavorare su tutte le tipologie di pneumatici, super ribassati, run-flat e cerchi in lega leggera.
- SP2300 **WDK**, che si differenzia da quella base per la presenza del disco invece che il rullo premitallone.



The **SP2300** is a practical and functional Helper device specifically designed to make mounting and demounting operations quicker, more precise and safer.

Two versions are available:

- SP2300 **Standard**, consisting of three integrated operating units capable of working on all types of tyre - including ultra low profile and run flat tyres - and light alloy wheel rims.
- SP2300 **WDK**, which differs from the standard version in having a bead depressor disc instead of a bead depressor roller.



Die Vorrichtung **SP2300** ist eine bequeme und funktionelle Helper, die eigens entwickelt wurde, um die Montage- und Demontearbeiten schneller, genauer und sicherer zu machen.

Erhältlich in zwei Ausführungen:

- SP2300 **Standard**, bestehend aus drei integrierten Arbeitsgruppen, die an allen Reifenarten wie Superniederquerschnittreifen, Runflat-Reifen und Leichtmetallfelgen arbeiten können.
- SP2300 **WDK**, die sich von der Basisausführung durch das Vorhandensein einer Scheibe anstelle der Wulstniederhalterrolle unterscheidet.

SCHEMA CONFIGURAZIONE DA ORDINARE - CONFIGURATION TO BE ORDERED - SCHEMA DER ZU BESTELLENDE KONFIGURATION

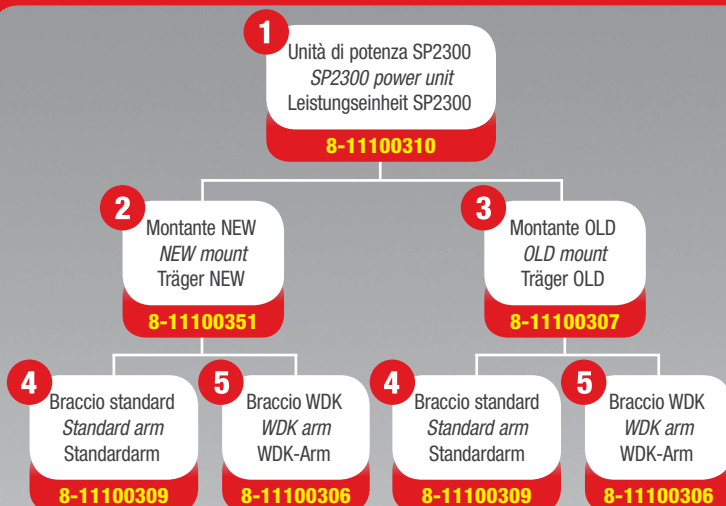

1 + 2 + 4

SP2300 STANDARD per smontagomme leggeri dal 2004* - for car tyre changers from 2004* - für PKW-Reifenmontiermaschinen ab 2004*

1 + 2 + 5

SP2300 WDK per smontagomme leggeri dal 2004* - for car tyre changers from 2004* - für PKW-Reifenmontiermaschinen ab 2004*

1 + 3 + 4

SP2300 STANDARD per A210 e smontagomme leggeri dal 1999 al 2004 - for A210 and car tyre changers from 1999 to 2004 - für A210 und PKW-Reifenmontiermaschinen von 1999 bis 2004

1 + 3 + 5

SP2300 WDK per A210 e smontagomme leggeri dal 1999 al 2004 - for A210 and car tyre changers from 1999 to 2004 - für A210 und PKW-Reifenmontiermaschinen von 1999 bis 2004

SP2300 STANDARD



● **RULLO CONICO.** Facilita le operazioni di smontaggio e montaggio primo tallone, mantenendo il tallone nel canale del cerchio. **A** Agevola la fase di smontaggio del secondo tallone. ● **TAPERED ROLLER.** Facilitates demounting and mounting of first bead by keeping the bead within the rim well. **A** Facilitates demounting of second bead. ● **KEGELROLLE.** Vereinfacht die Arbeiten für die Demontage und Montage des ersten Wulsts, indem der Wulst im Felgenbett gehalten wird. **A** Erleichtert die Demontage des zweiten Wulsts.



● Il **DISCO GRANDE** consente il sollevamento del pneumatico e il distacco del tallone inferiore. ● **The LARGE DISC** lifts the tyre and detaches the lower bead. ● Die **GROSSE SCHEIBE** gestattet das Anheben des Reifens und das Lösen des unteren Wulsts.



● **PREMITALLONE ROTANTE.** Segue radialmente il pneumatico nelle operazioni di montaggio e smontaggio, con l'ausilio del rullo premitallone o in alternativa del disco WDK. ● **ROTATING BEAD DEPRESSOR.** Follows the tyre radially during mounting and demounting and depresses the bead with a roller or, in the case of the WDK version, a disc. ● **ROTIERENDER WULSTNIEDERHALTER.** Folgt dem Reifen während der Montage- und Demontearbeiten radial mit Hilfe der Wulstniederhalterrolle oder alternativ dazu der WDK-Scheibe.



SP2300 WDK

● **VERSIONE WDK** con il disco al posto del rullo. Insieme all'applicazione della procedura WDK, garantisce operazioni di lavoro omologate. ● **WDK VERSION** with disc instead of roller. Used in conjunction with WDK procedure to ensure compliance with WDK requisites. ● **WDK-AUSFÜHRUNG** mit Scheibe anstelle der Rolle. In Verbindung mit der Anwendung des WDK-Verfahrens gewährleistet sie, dass die Arbeiten den WDK-Vorgaben entsprechen.



ACCESSORIO A RICHIESTA - OPTIONAL ACCESSORY - OPTIONALES ZUBEHÖR



- Bloccaggio del cerchio sulla morsa con l'ausilio del **CONO PREMI CERCHIO**.
- Rim locked onto clamp with **RIM PRESSER CONE**.
- Einspannen der Felge am Spanntisch mit Hilfe des **FELGENNIEDERHALTEKEGELS**.

8-11100311

DATI TECNICI

campo di lavoro	fino a 26"
altezza massima ruota	14"
forza di pressione su utensili	7000 N
alimentazione	pneumatica
pressione di esercizio	10 bar
peso versione standard	53 Kg
peso versione WDK	53 Kg

TECHNICAL DATA

working range	up to 26"
maximum wheel height	14"
press force on tools	7000 N
compressed air	supply
operating pressure	10 bar
weight, standard version	53 Kg
weight, WDK version	53 Kg

TECHNISCHE DATEN

Einsatzbereich	bis 26"
Max. Radhöhe	14"
Druckkraft an den Werkzeugen	7000 N
Spannungsversorgung	Pneumatik
Betriebsdruck	10 bar
Gewicht Standardausführung	53 Kg
Gewicht WDK-Ausführung	53 Kg

DIMENSIONI DI INGOMBRO - OVERALL DIMENSIONS - ABMESSUNGEN

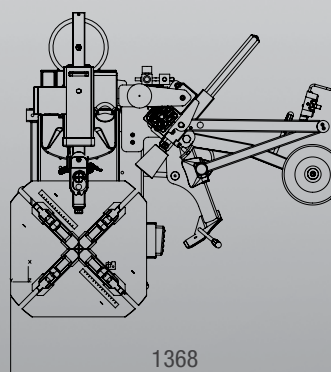
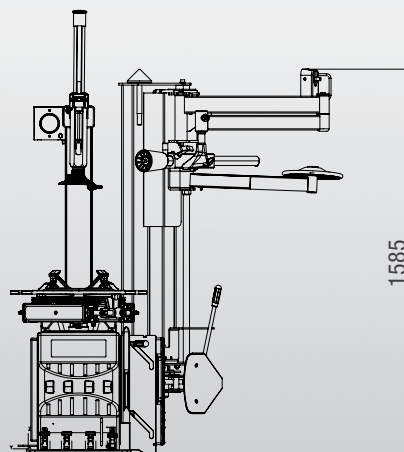

Fotografie, caratteristiche ed i dati tecnici non sono vincolanti, possono subire modifiche senza preavviso. The manufacturer reserves the right to modify the features of its products at any time. Les photographes, les descriptions et les données techniques ne sont pas contraignantes. Le fabricant se réserve le droit d'apporter des modifications sans préavis. Fotografieren, Eigenschaffen und technische Daten sind nicht bindend und können ohne Vorankündigung geändert werden. Las fotografías, las características y los datos técnicos no son vinculantes. La empresa se reserva el derecho de modificaciones en cualquier momento. As fotografias, as características e os dados técnicos não são vinculantes, podem ser modificados sem prévio aviso. Code: DFC6000357B 07-2013

Per aiutare il pianeta ottimizzando il consumo di carta, i nostri cataloghi sono consultabili sul sito www.corghi.com. Una stampa responsabile aiuta a preservare l'ambiente. To protect the planet and reduce paper usage, our catalogues are viewable online at the website www.corghi.com. Printing responsibly contributes to saving the environment.

