



# AUTOMASTER

THE AUTO EQUIPMENT SPECIALISTS

## Peak P-209C-S

4000kg 2 Post Clear Floor Hoist



# PEAK®

ALSO AVAILABLE  
IN BLUE



# Peak P-209C-S

## 4000kg 2 Post Clear Floor Hoist



**OUR VICE-GRIP GUARANTEE**

If you're not happy, we replace or refund in full.



4 three-stages arms are suitable for a wide range of vehicles.

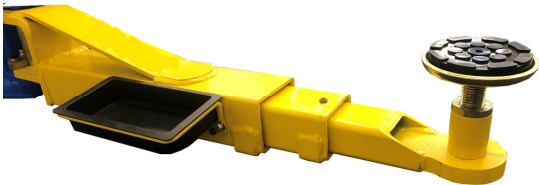

Quality alloy body electric motor

Manual down valve

### FEATURES

- Only 100mm concrete thickness required (minimum)
- 4000kg (9,000lbs) capacity.
- Full length dual hydraulic direct-drive cylinders minimizes the number of moving parts to maintain and repair
- 4 three-stages arms are suitable for easy load of a large range of cars, vans & 4x4's
- 3/8" aircraft quality cable is used for balancing
- Single-point safety release, allow technician to disengage both column simultaneously.
- Self-lubricating UHMW Polyethylene sliders and bronze bushes.
- Clear-floor design, provides unobstructed floor use.
- Overhead safety shut-off device prevents vehicle damage.
- Screw up feet and 2.5" adapters as standard
- Large rubber door guards attached to each carriage
- Standard toe guards & 2 x tool trays on lifting arms.
- Two height setting for top cross bar accommodates varying ceiling heights
- Low service costs
- Optional 610mm Height Extension - (Height 4431mm)
- Optional 150mm Width Extension Kit - (Width 3000mm)
- European CE Safety Certified
- Full 2 year warranty



Self-lubricating bronze bush, no need frequently change.



The stackable rubber pads assembly with 2.5" extension adapters.

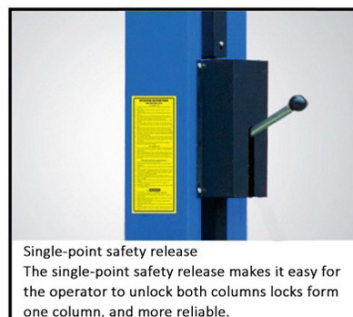

Single-point safety release  
The single-point safety release makes it easy for the operator to unlock both columns locks form one column, and more reliable.



Hydraulic Direct-driven Cylinders.  
The hydraulic direct-driven cylinders feature more efficient, more longevity, more reliable and less service.



Optional Width Extension Kits  
With these kits the width between posts is adjusted from 2850mm to 3000mm.  
Kits No.:20906



Optional Height Extension Kits.  
With these kits the overall height is adjusted from 3821mm to 4431mm.  
Kits No.:20902

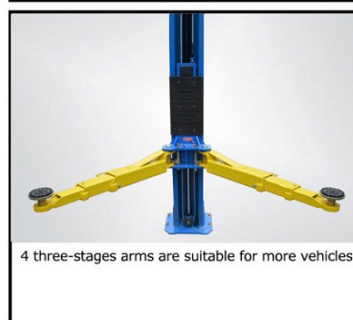

4 three-stages arms are suitable for more vehicles.

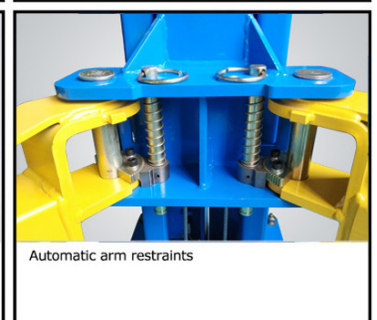

Automatic arm restraints

# Peak P-209C-S

## 4000kg 2 Post Clear Floor Hoist



**OUR VICE-GRIP GUARANTEE**  
If you're not happy, we replace or refund in full.

# PEAK®

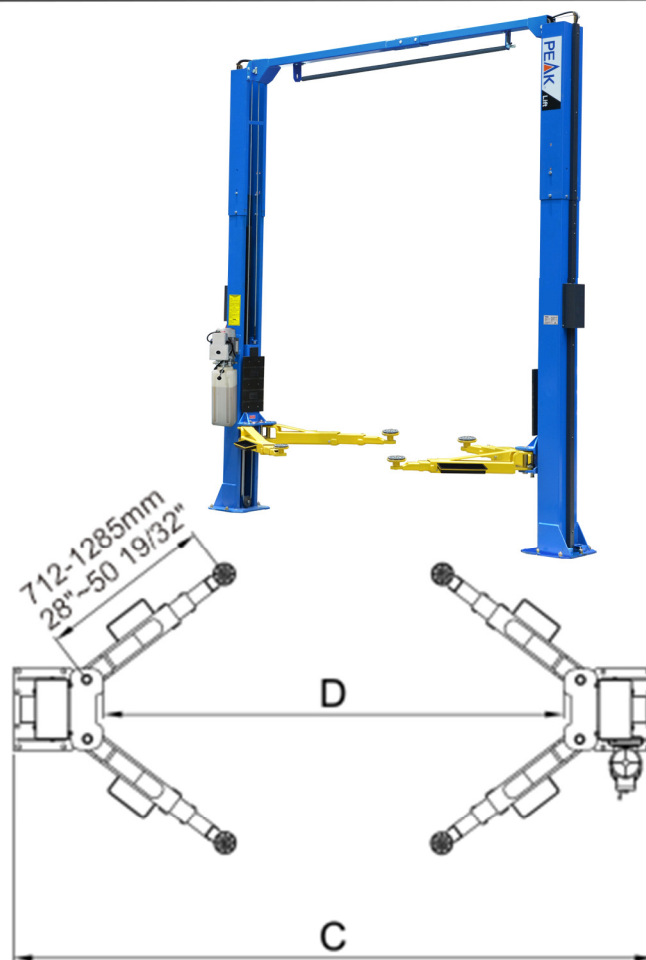
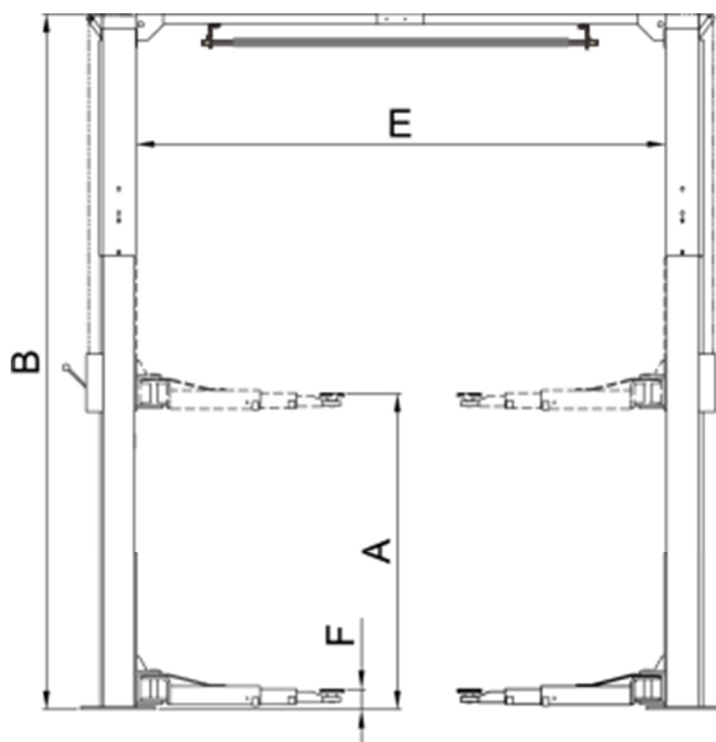

Model 209C	Clear Floor two post lift
Lifting Capacity	4000kg (9,000 lbs)
Lifting Time	57s
Max. Lifting height: (w/o extension adapter)	1815mm (71 1/2") ~1863mm(73 3/8")
Max. Lifting height: (w/ extension adapter)	1891mm (74 7/16")~1939mm(76 5/16")
Max. lock height: (w/o extension adapter)	A 1768mm (69 5/8" )~1816mm(71 1/2")
Max. lock height: (w/ extension adapter)	1844mm (72 5/8" )~1892mm(74 1/2")
Overall Height	B 3635mm (143 1/8") 3835mm (151")
Overall Width	C 3428mm (135")
Drive-Thru Clearance	D 2528mm (99 1/2")
Width Between Columns	E 2850mm (112 7/32")
Minimum Pad Height	F 89mm (3 1/2")
Gross Weight	695kg (1,369 lbs)
Motor	3.0HP
QTY of Container	25 Units/20'GP 50 Units/40'GP
Packing Dimension	2800 X 450 X 825 mm