



Peak P-210CXH-S

4500kg 2 Post Clear Floor Hoist



PEAK[®]

**WIDER
TALLER
HIGHER LIFT HEIGHT**



Peak P-210CXH-S

4500kg 2 Post Clear Floor Hoist



OUR VICE-GRIP GUARANTEE

If you're not happy, we replace or refund in full.



4 three-stage arms are suitable for a wide range of vehicles.

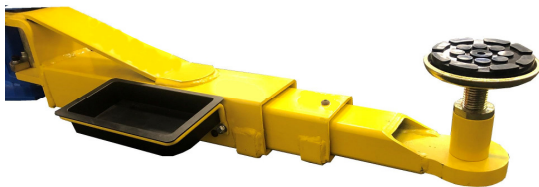

FEATURES

- Only 100mm concrete thickness required (minimum)
- 4500kg (9,000lbs) capacity.
- 210CHX is a new extremely high lifting 2 post lift, reaching up to 2000mm (excluding the extension adapters)
- the 210CHX utilizes extremely long carriages, which are 2 times longer than most of competitor's products.
- Wide clearance of 3000mm between the columns
- Full length dual hydraulic direct-drive cylinders minimizes the number of moving parts to maintain and repair
- 4 three-stage arms are suitable for easy load of a large range of cars, vans & 4x4's
- 3/8" aircraft quality cable is used for balancing
- Single-point safety release, allow technician to disengage both column simultaneously.
- Self-lubricating UHMW Polyethylene sliders and bronze bushes.
- Clear-floor design, provides unobstructed floor use.
- Overhead safety shut-off device prevents vehicle damage.
- Screw up feet and 2.5" adapters as standard
- Large rubber door guards attached to each carriage
- Standard toe guards & 2 x tool trays on lifting arms.
- Two height setting for top cross bar accommodates varying ceiling heights
- European CE Safety Certified
- Full 2 year warranty

| SPECIFICATIONS | |
|------------------------|------------------------|
| Capacity | 4500KG |
| Max height | 2000mm |
| With extension adapter | 2229mm |
| Min Height | 90mm |
| Lifting Time (approx) | 60 Sec |
| Width Between Columns | 3000mm |
| Power supply | 230V 1PH |
| Total height | low 4035mm/4313mm high |
| Warranty | 2 years |

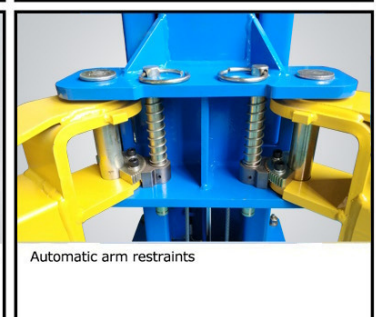
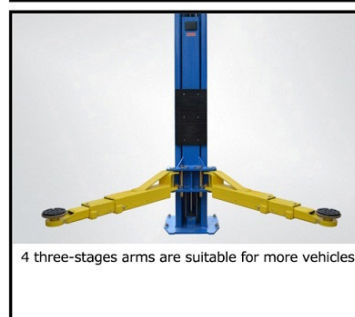
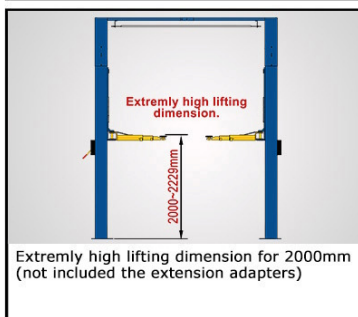
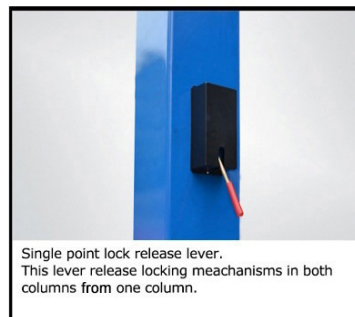

Peak P-210CXH-S

4500kg 2 Post Clear Floor Hoist



OUR VICE-GRIP GUARANTEE

If you're not happy, we replace or refund in full.



Quality alloy body electric motor

Manual down valve

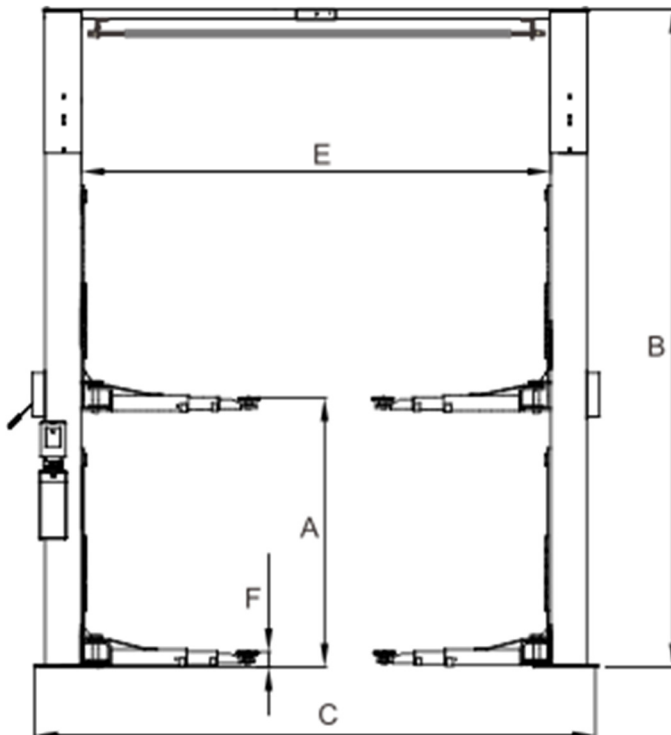

Max. Lifting height: (w/o extension adapter)

2000mm (78 3/4")

Max. Lifting height: (w/ extension adapter)

2229mm (87 3/4")

Max. lock height: (w/o extension adapter)

A 1960mm (77 5/32")

Max. lock height: (w/ extension adapter)

2189mm (86 3/16")

Overall Height

B 4313mm (169 13/16")

4035mm (158 7/8")

Overall Width

C 3666mm (144 11/32")

Drive-Thru Clearance

D 2710mm (106 11/16")

Width Between Columns

E 3000mm (118 1/8")

Minimum Pad Height

F 90mm (3 9/16")