

AM-6255TD

# 5.5T Capacity 2 Post Lift With Twin Hydraulic Rams



↑  
Foam covered roof  
Protection cut out

←  
Single point  
safety lock  
release

## Post Height Settings

5200mm  
5320mm  
5420mm

## 24v Controls

Our lifts are  
fitted with a  
low voltage  
control system

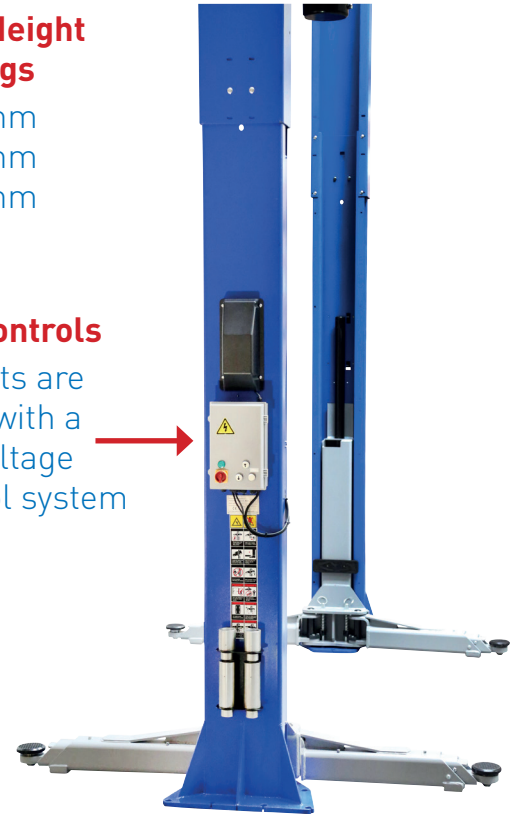

Automatic arm locks

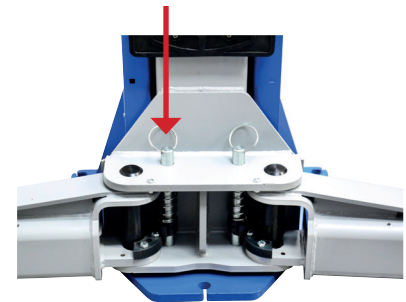

## 3 Stage Symmetrical Telescopic Arms

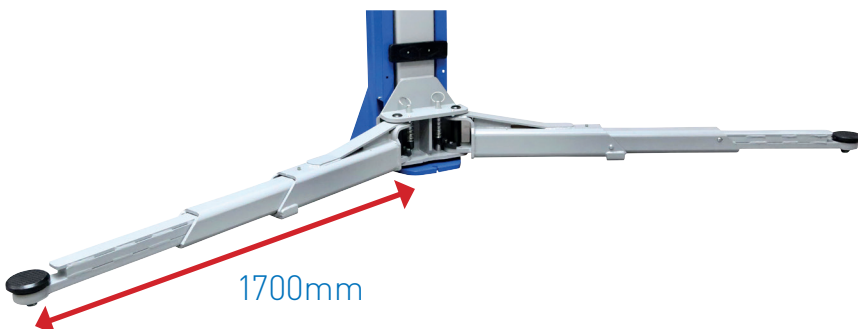

1700mm

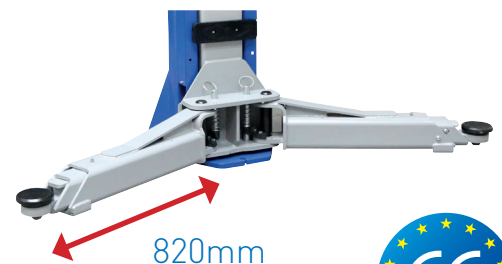

820mm



AM-6255TD

# 5.5T Capacity 2 Post Lift With Twin Hydraulic Rams



Includes 2 sets of lift pad extensions and arm extensions

Double thread adjustable lift pads

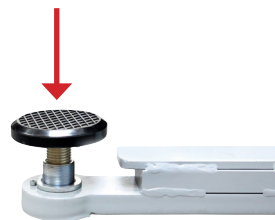

### Lift Pad Extensions

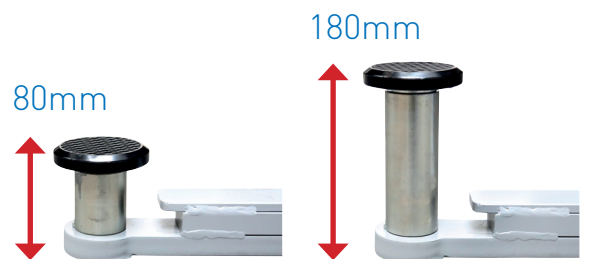

### Arm extensions

This gives a maximum arm length of 1950mm

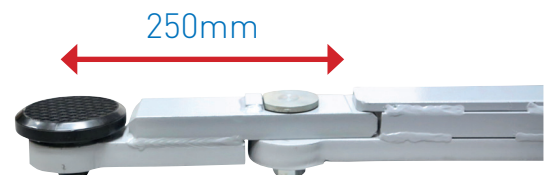

AM-6255TD

# 5.5T Capacity 2 Post Lift With Twin Hydraulic Rams



## Dimensions in mm

